



US 20050086895A1

(19) **United States**

(12) **Patent Application Publication**

Elliot et al.

(10) **Pub. No.: US 2005/0086895 A1**

(43) **Pub. Date: Apr. 28, 2005**

(54) **COMPRESSION POST FOR STRUCTURAL SHEAR WALL**

(52) **U.S. Cl. 52/633**

(76) Inventors: **A. Carleton Elliot**, Newport Beach, CA (US); **Allan J. Swartz**, Gardnerville, NV (US); **Gregory Kulpa**, Tustin, CA (US)

(57) **ABSTRACT**

Correspondence Address:
KNOBBE MARTENS OLSON & BEAR LLP
2040 MAIN STREET
FOURTEENTH FLOOR
IRVINE, CA 92614 (US)

A compression post for a shear wall includes a plate mounted to the bottom of an end post of a shear wall. The plate is sized to conform to the lower end of each end post. An extended portion (e.g., a cylinder) is positioned perpendicularly to the plate. The extended portion has a cross section sized to fit through a hole in a mudsill of the shear wall and has a length selected to conform with a thickness of the mudsill. When the shear wall is mounted on a structural support (e.g., a footing or foundation), forces applied to the end post pass through the plate and the extended portion to the structural support. The extended portion may be secured to the plate (e.g., by spot welding, press fitting, bolting, or threaded engagement) or the two portions may be independent. The two portions may also be a cast unitary body.

(21) Appl. No.: **10/773,757**

(22) Filed: **Feb. 6, 2004**

Related U.S. Application Data

(60) Provisional application No. 60/515,150, filed on Oct. 27, 2003.

Publication Classification

(51) **Int. Cl.⁷ E04C 3/02**

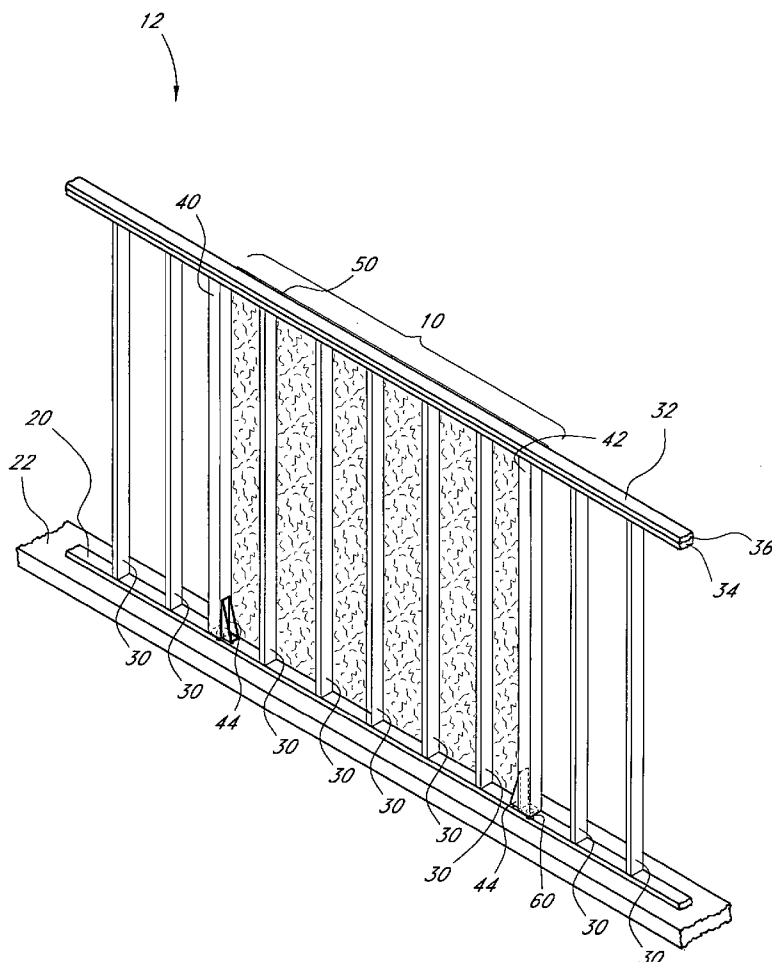

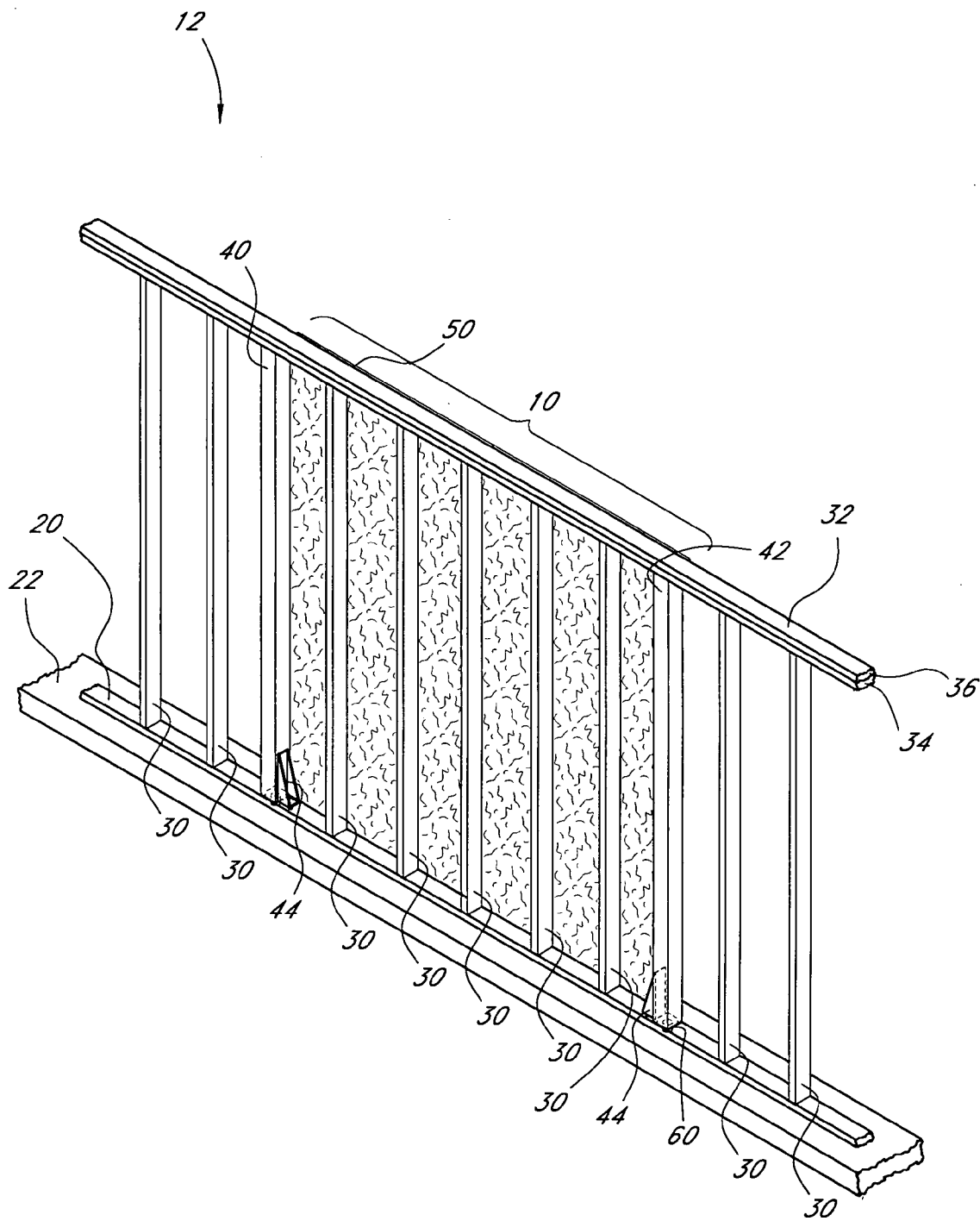

FIG. 1

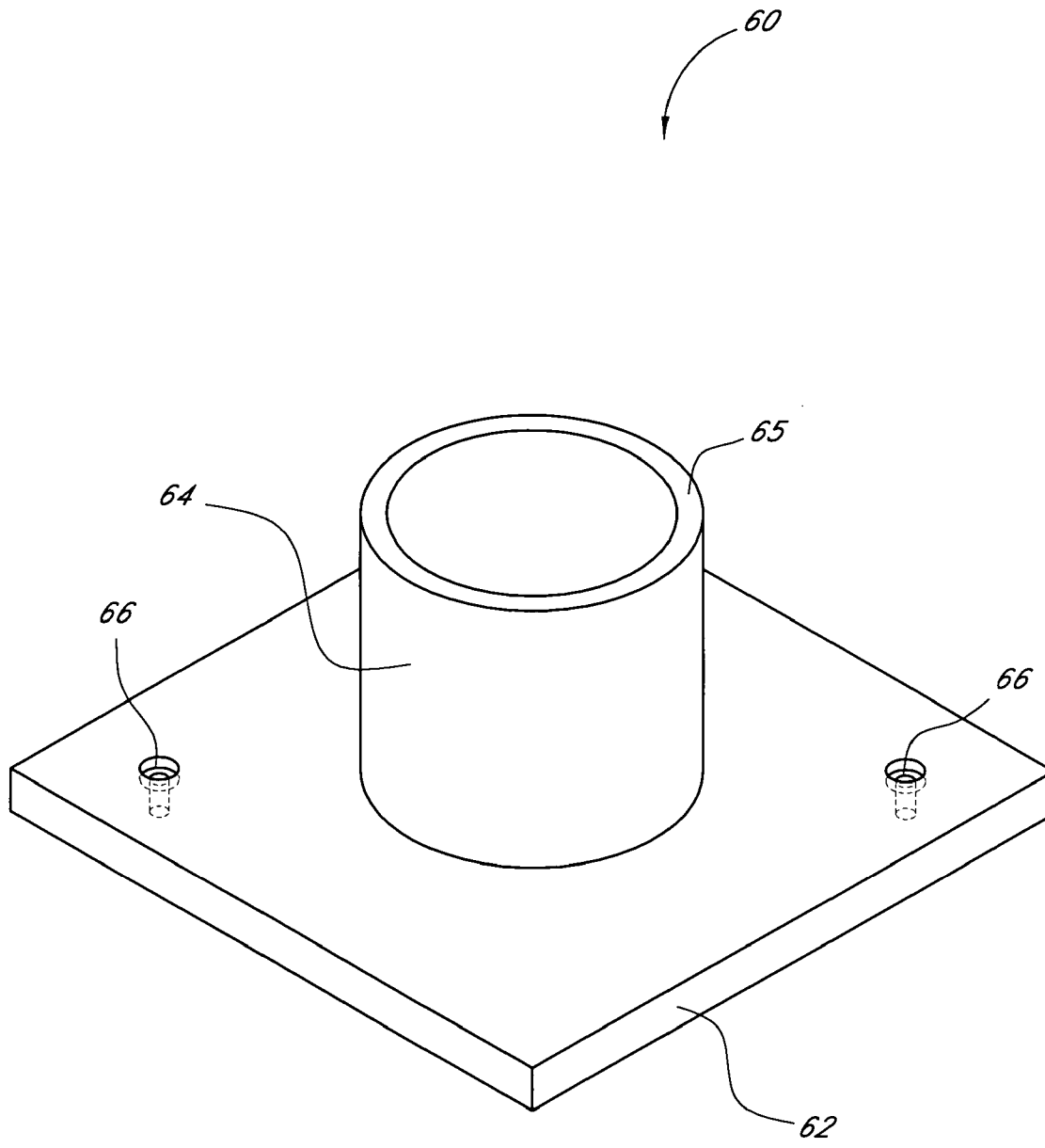

FIG. 2

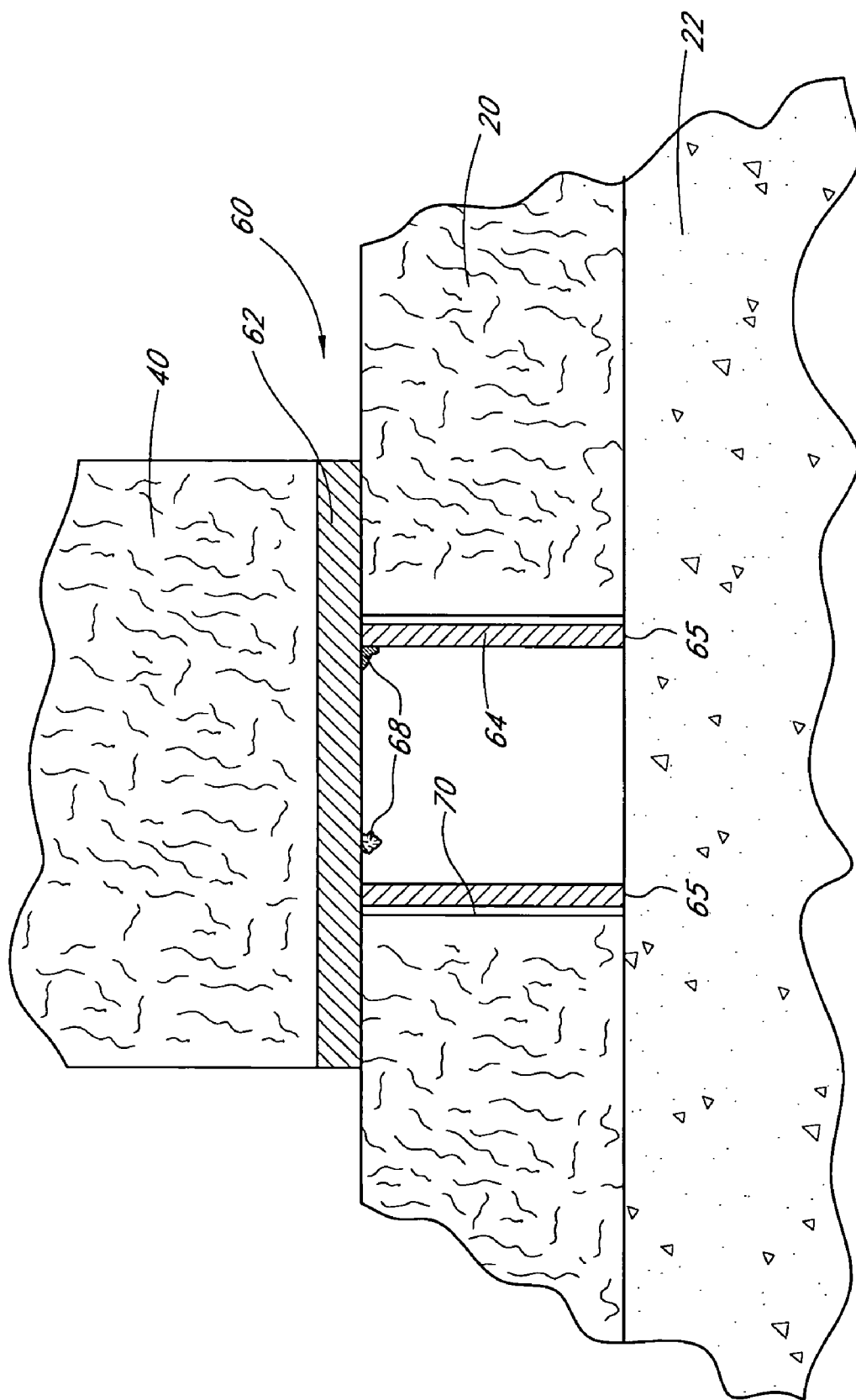

FIG. 3

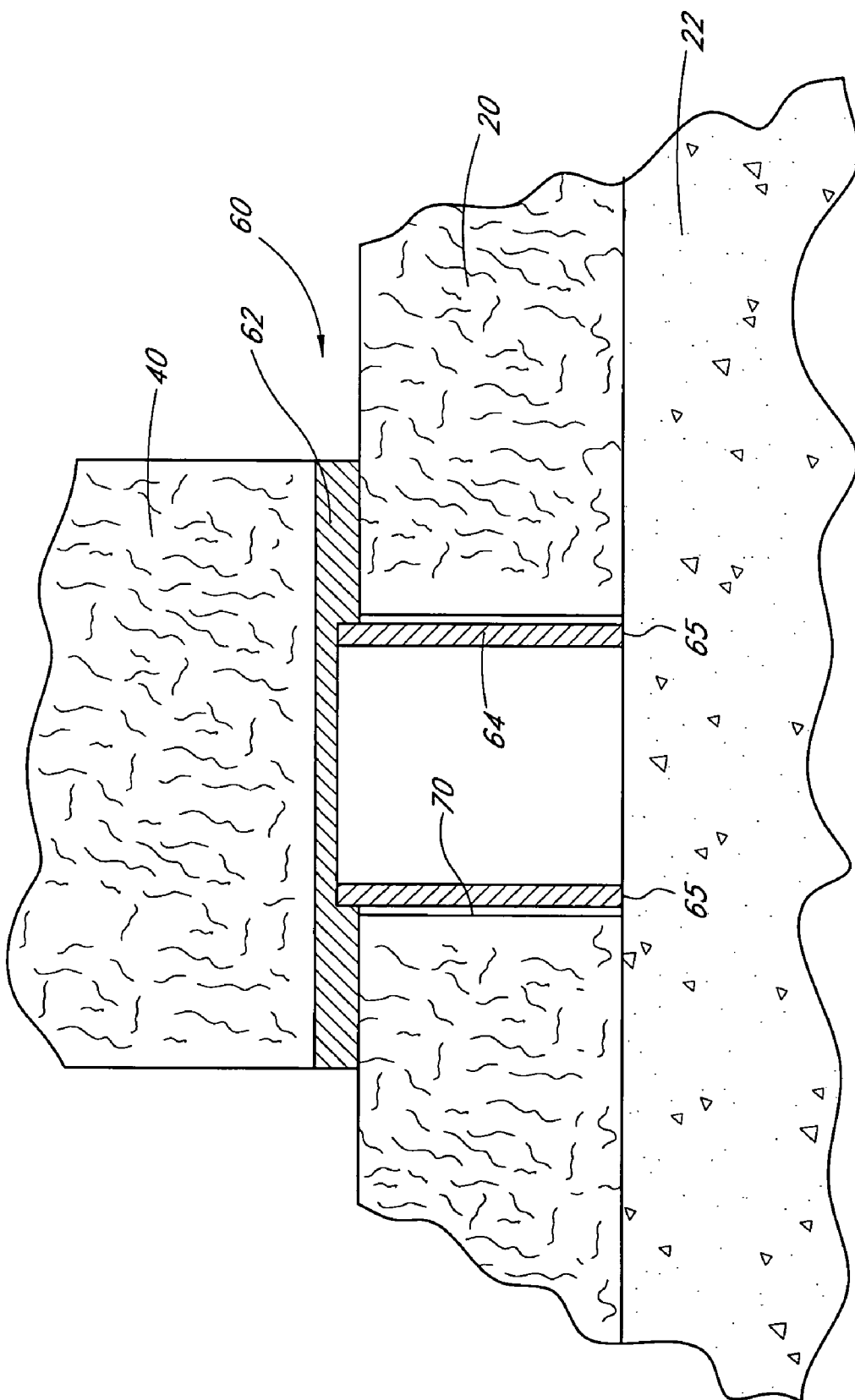

FIG. 4

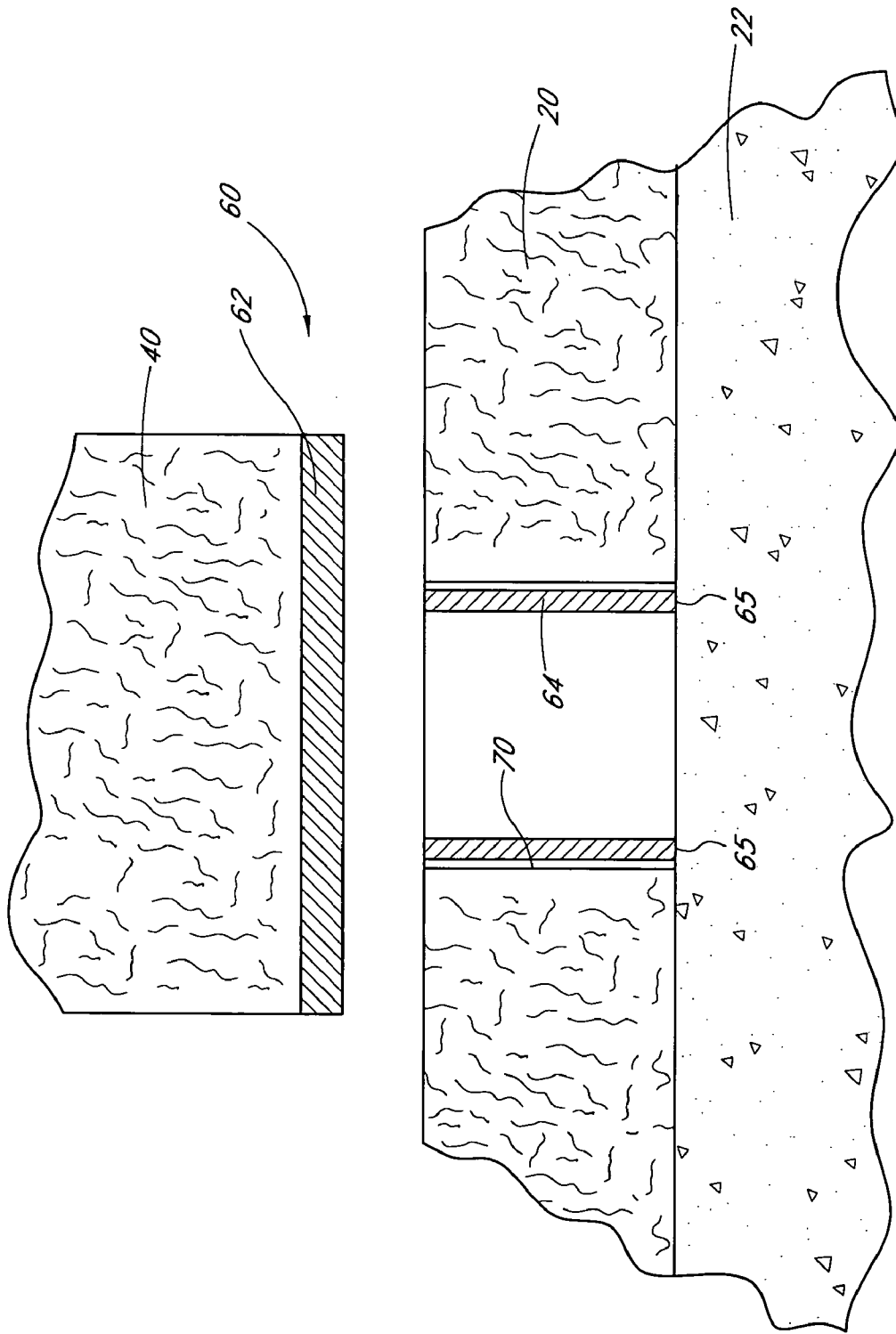

FIG. 5

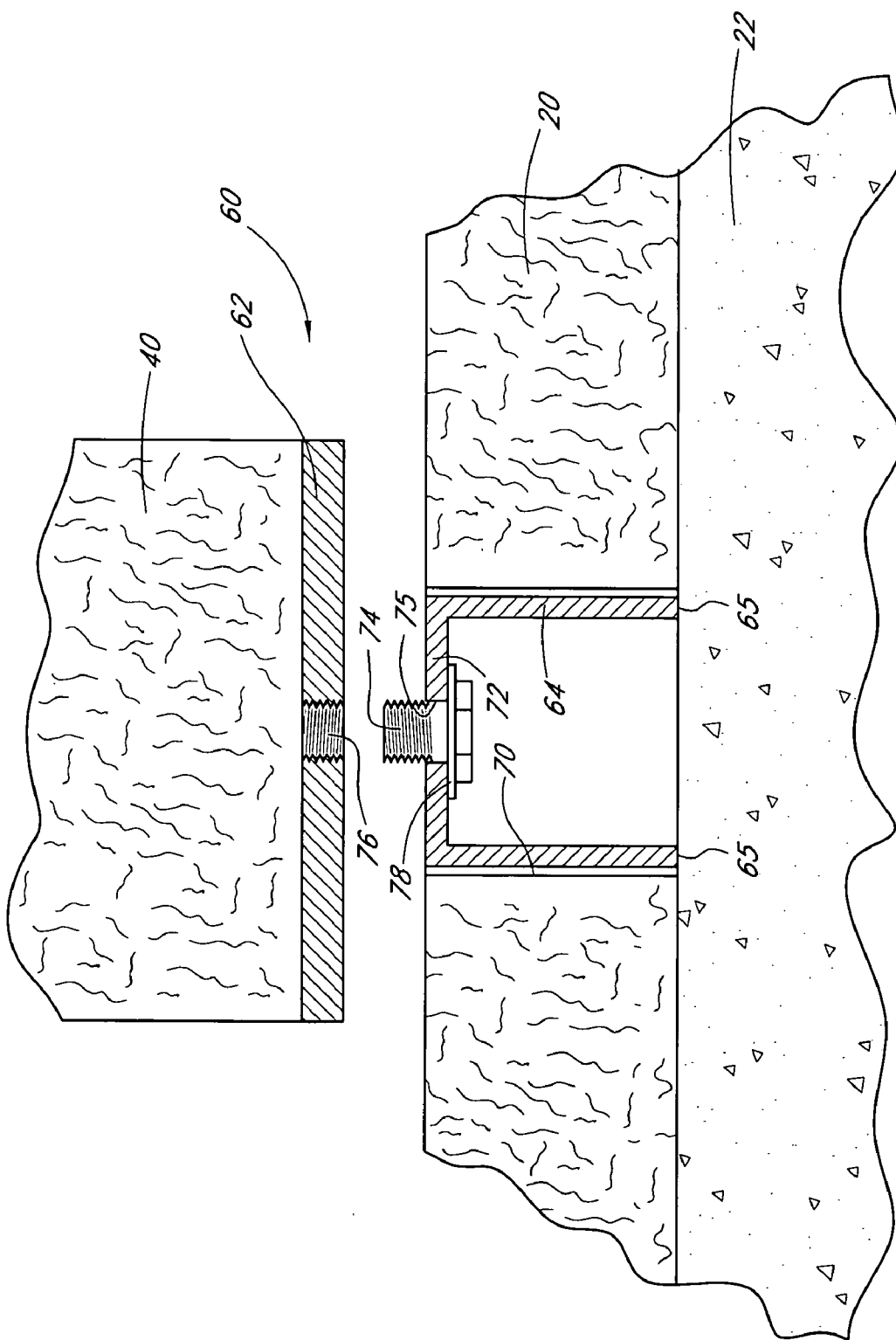

FIG. 6

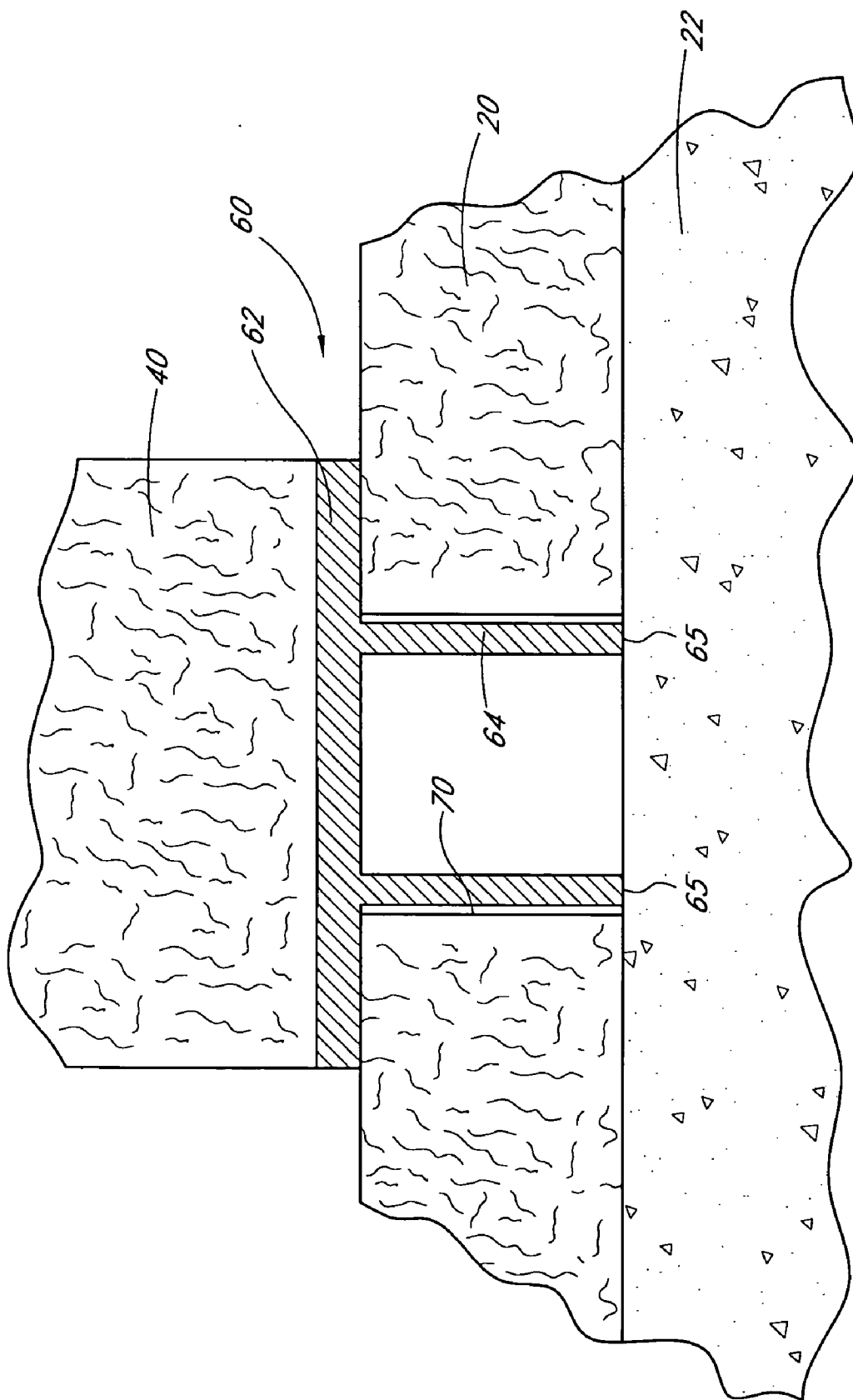

FIG. 7

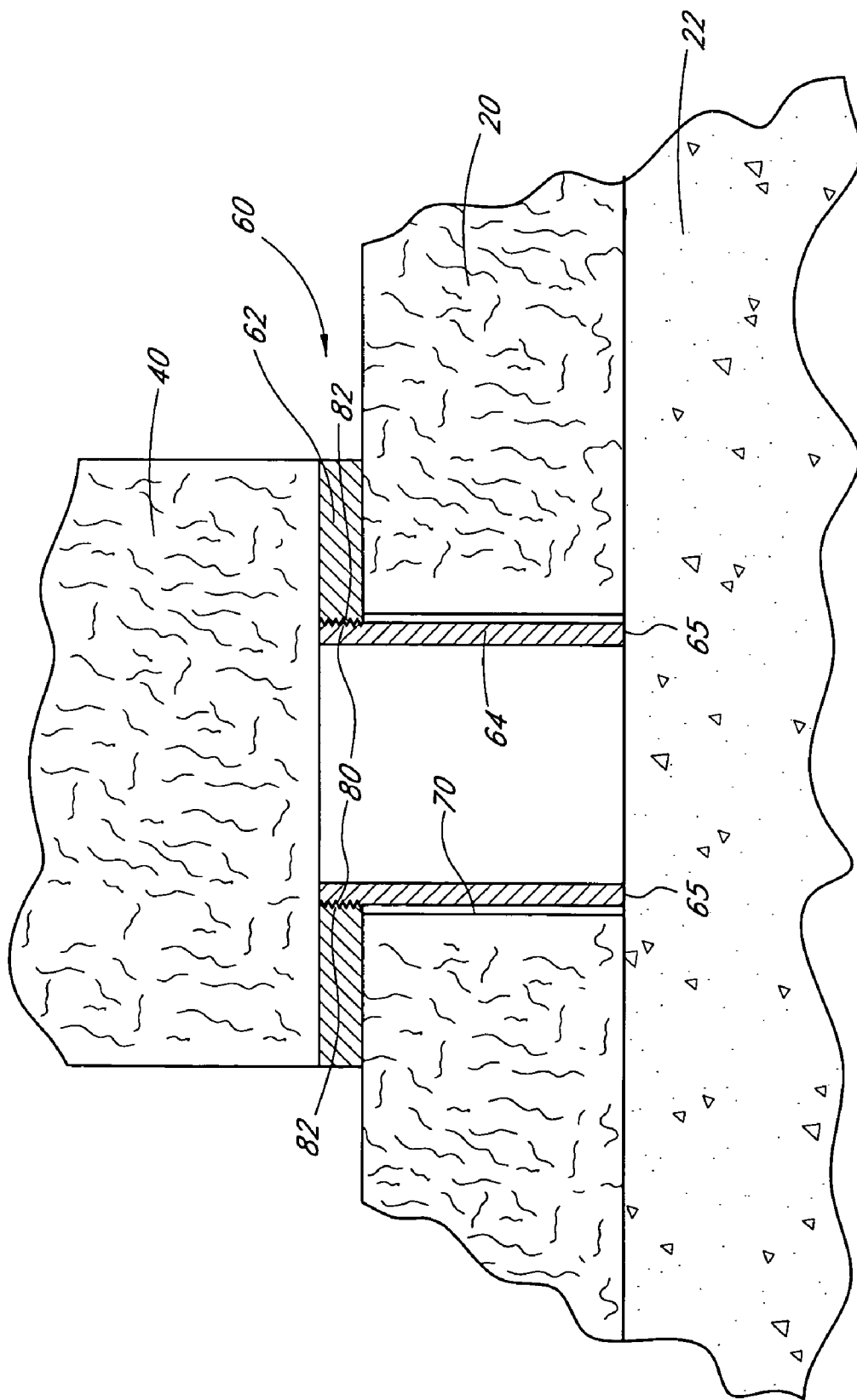

FIG. 8

COMPRESSION POST FOR STRUCTURAL SHEAR WALL

RELATED APPLICATIONS

[0001] The present application claims the benefit of priority under 35 U.S.C. § 119(e) of U.S. Provisional Application No. 60/515,150, filed on Oct. 27, 2003.

BACKGROUND OF THE INVENTION

[0002] 1. Field of the Invention

[0003] The present invention is in the field of elements for use in construction, and, more particularly, is in the field of construction elements for reducing damage caused to structures during seismic events, severe wind events and other forces applied to structures.

[0004] 2. Description of the Related Art

[0005] During a seismic event, such as an earthquake, or during a severe wind event, a structure may be subjected to large forces which can result in severe damage or total destruction of the structure. Conventional walls of a residential structure comprise a lower mudsill that rests on a concrete footing or other suitable foundation. An upper double top plate is spaced apart from the mudsill with a plurality of vertical studs which are generally evenly spaced (e.g., sixteen inches or twenty-four inches on center (“o/c”). The outer portion of a conventional wall is sheathed with plaster, siding or other suitable material, and the inner portion is covered with gypsum board, paneling or the like. Such a conventional wall cannot withstand the forces of seismic event or severe wind event because the shape of the wall distorts when the upper portion of the conventional wall moves laterally with respect to the mudsill. Even if the structure withstands the seismic event, the lateral movement of the wall causes cracks, broken windows and the like. In many cases, the wall does not return to its original shape after the seismic event or wind event is over.

[0006] In order to reduce the likelihood of structural damage during a seismic event or wind event, many residential structures are now constructed with shear walls. In particular, at least a portion of each of the inner and outer walls comprises a shear wall. A shear wall may comprise a specially constructed section of any wall which is constructed at a building site. Alternatively a shear wall may comprise a panel constructed separately and inserted into any wall at the building site. Both types of shear walls are included within the scope of the following description.

[0007] Unlike a conventional wall, a shear wall includes a solid structural sheet positioned over the outer surface or the inner surface. The solid structural panel of the shear wall may advantageously comprise one or more plywood sheets of suitable thickness. Alternatively, the shear wall may comprise a laminated panel of steel or another metallic material. See, for example, U.S. Pat. No. 5,768,841 to Swartz et al. for Wallboard Structure. Each end of the shear wall comprises a larger vertical member (e.g., an end post) to which the solid structural sheet is also attached. For example, the end posts may advantageously comprise a conventional 4×4 or larger post. During seismic events or severe wind events, the forces applied to the shear wall are coupled to the foundation via the end posts. Furthermore, the end posts are secured to the foundation via hold down

devices, such as, for example, the hold down connector shown in U.S. Pat. No. 5,249,404 to Leek et al. for Holddown Structure.

[0008] The solid structural sheet of the shear wall inhibits the movement of the upper double top plate with respect to the mudsill when force is applied. Thus, the shear wall does not distort. By tying the remaining portion of any wall to the shear wall, movement of the entire wall is inhibited, and damage caused by the force is substantially reduced.

[0009] Although shear walls reduce the damage during seismic events, studies have shown that during very large seismic events or severe wind events, the forces applied to the shear wall and coupled to the end posts are sufficiently large to cause the lower ends of the end posts to compress the mudsill. The wood fibers in the compressed mudsill are crushed to reduce the thickness of the mudsill. The reduced thickness of the mudsill allows more movement of the shear wall, and thus may result in severe damage or destruction of the structure.

[0010] Because of the compression of the mudsill, building codes have been revised recently to require the mudsill of the shear wall to be constructed from larger material. For example, instead of allowing a contractor to use a conventional 2×4 or 2×6 material having a nominal thickness of 1.5 inches, the contractor is required to use a 3×4 or 3×6 mudsill having a nominal thickness of 2.5 inches to substantially reduce compression of the mudsill of the shear wall.

[0011] The additional thickness of the mudsill would appear to be a relatively straightforward way of reducing damage caused by seismic events and severe wind events; however, the thicker mudsill causes additional construction expenses for a contractor. For example, three-inch thick lumber is non-conventional. Thus, a contractor has to special order 3×4 or 3×6 lumber to construct the mudsill or create the mudsill at the construction site from larger material. In addition, the conventional studs between the mudsill and the double top plate have to be cut to be one inch shorter than conventional studs. Although this might appear to be a minor inconvenience, it should be understood that hundreds or thousands of studs are used at a large number of construction sites (e.g., at a new housing development or a new apartment complex). The additional time required to cut each stud rather than using the studs as delivered from the lumber supplier adds substantial cost and waste to a large construction project. Furthermore, since the required thickness of the 3×4 or 3×6 mudsill is 2.5 inches thick, the carpenters building walls with such mudsills must use larger nails to connect the mudsill to the bottoms of the studs. The larger nails are more expensive. In addition, the larger nails do not work with conventional nail guns. Since the economies of modern construction depend on the use of nail guns as well as other power tools to reduce construction time, the loss of the use of the nail gun for such repetitive work has a significant economic impact on the profit of the contractor or the cost to the owner of the finished structure. Thus, an alternative to the thicker mudsill is needed.

SUMMARY OF THE INVENTION

[0012] One aspect of the present invention is a construction element to inhibit compression of a mudsill by the end posts of a shear wall and thereby eliminate the requirement for a thicker mudsill. The construction element is referred to

herein as a compression post. The compression post comprises steel or other suitable material mounted to the lower end of an end post of a shear wall. The compression post comprises a plate that attaches the compression post to the lower end of the end post. The compression post further comprises an extended portion (e.g., a cylinder) positioned generally perpendicularly to the plate. The extended portion has a length selected to be at least as great as the thickness of the mudsill such that a free end of the extended portion rests on the structural support (e.g., a footing or foundation) beneath the mudsill. The extended portion is sized to pass through a hole in the mudsill. When the shear wall is mounted on the structural support, the free end of the extended portion rests on the structural support. Forces applied to the end post during a seismic event or during a severe wind event are communicated from the end post to the structural support via the compression post such that the mudsill experiences substantially no compression during the event.

[0013] Another aspect in accordance with embodiments of the present invention is a shear wall mountable on a structural support such as a footing or a foundation. The shear wall has a first end, a second end, a bottom and a top. The shear wall comprises a mudsill at the bottom of the shear wall, a double top plate at the top of the shear wall, a plurality of studs positioned between the mudsill and the double top plate, a first end post at the first end of the shear wall, and a second end post at the second end of the shear wall. The first end post and the second end post have respective lower ends. A structural sheet is mounted to the mudsill, the double top plate, the studs, the first end post and the second end post to form a rigid structure. The shear wall further comprises a first compression post positioned at the lower end of the first end post and a second compression post positioned at the lower end of the second end post. Each compression post comprises a plate mounted to the respective lower end of the respective end post. The plate has dimensions selected to conform to the lower end of the end post. Each compression post further comprises an extended portion positioned perpendicularly to the plate. The extended portion has at least one dimension selected so that the extended portion fits through a hole in the mudsill. The extended portion has a length selected to conform to a thickness of the mudsill. When the shear wall is mounted on the structural support, forces applied to the end post are communicated via the plate and the cylinder to the structural support.

[0014] Another aspect in accordance with embodiments of the present invention is a method of reducing the lateral movement of a shear wall during a seismic event or a wind event. The method comprises constructing a shear wall having a first end post and a second end post mounted between a mudsill and a double top plate. The method further comprises positioning a respective compression post on a lower end of each end post. The compression post has an extended portion that passes through a hole in the mudsill. The method further comprises positioning the shear wall on a structural support (e.g., a footing or a foundation) with respective exposed ends of the extended portions of the compression posts resting on the structural support. Forces applied to the end posts are communicated to the structural support via the compression posts rather than via the mudsills.

BRIEF DESCRIPTION OF THE DRAWINGS

[0015] These and other aspects of the present invention are described below in connection with the accompanying drawings in which:

[0016] **FIG. 1** illustrates a perspective view of a shear wall incorporating a compression post in accordance with an embodiment of the present invention;

[0017] **FIG. 2** illustrates a perspective view of an embodiment of the compression post having a generally rectangular plate and a cylindrical extended portion;

[0018] **FIG. 3** illustrates a cross-sectional elevational view of the compression post mounted on the bottom of an end post with the extended portion of the compression post inserted through a hole in a mudsill, wherein the extended portion is spot-welded to the plate;

[0019] **FIG. 4** illustrates a cross-sectional elevational view of an alternative embodiment of the compression post with the extended portion inserted through a hole in a mudsill, wherein the extended portion is press-fit into the plate portion;

[0020] **FIG. 5** illustrates a cross-sectional elevational view of an alternative embodiment of the compression post in which the plate and the extended portion are independent prior to installation of the plate extended portion in a shear wall;

[0021] **FIG. 6** illustrates a cross-sectional elevational view of an alternative embodiment of the compression post in which the extended portion is coupled to the plate by a fastening system;

[0022] **FIG. 7** illustrates a cross-sectional elevational view of an alternative embodiment of the compression post in which the extended portion and the plate are cast as a unitary body; and

[0023] **FIG. 8** illustrates a cross-sectional elevational view of an alternative embodiment of the compression post in which the extended portion is threaded into a threaded bore formed in the plate.

DETAILED DESCRIPTION OF THE PREFERRED EMBODIMENTS

[0024] **FIG. 1** illustrates an exemplary shear wall **10** into which embodiments in accordance with the present invention can be incorporated. In **FIG. 1**, the shear wall **10** comprises a section of a wall **12** of a structure (not shown). A lower portion of the shear wall **10** comprises a mudsill **20**, which extends beyond the shear wall **10** and which advantageously forms a common lower portion of the wall **12** such that the conventional wall construction is also mounted on the mudsill **20**. The mudsill **20** is mounted on a footing **22**, which may also be referred to as the foundation of the structure.

[0025] A plurality of studs **30** have their respective lower ends mounted to the mudsill **20** before the wall **12**, including the shear wall **10**, is erected and placed on the footing **22**. For example, the studs **30** are connected to the mudsill **20** via nails (not shown) driven through the bottom of the mudsill **20** and into the lower ends of the studs **30**. A double top plate **32** is mounted to respective upper ends of the studs **30**. One skilled in the art will appreciate that the double top plate **32**

conventionally comprises a first top plate portion **34** nailed directly to the upper ends of the studs **30** and a second top plate portion **36** nailed to the first top plate portion **34**.

[0026] The shear wall **10** further includes a first end post **40** and a second end post **42**. The end posts **40, 42** are spaced apart by a distance selected to provide an overall length for the shear wall **10**. The length may be selected, for example, to conform with building codes applicable to the location of the construction site. Preferably, respective hold down connectors **44** are attached to the end posts **40, 42** a plurality of bolts and nuts (not shown). The hold down connectors **44** engage bolts (not shown) embedded in the footing **22** and are secured by nuts (not shown) so that the end posts **40, 42** cannot lift from the footing **22** during a seismic event or a severe wind event. Exemplary hold down connectors and the associated nuts and bolts are disclosed, for example, in U.S. Pat. No. 5,249,404, the disclosure of which is incorporated by reference herein.

[0027] A structural sheet **50** is mounted on the shear wall using nails or other fasteners (not shown) to connect the structural sheet **50** to the end posts **40, 42**, the studs **30**, the mudsill **20** and the double top plate **32**. The thickness of the structural sheet **50**, the number of nails, and the spacing of the nails are determined by the applicable building code. After the structural sheet **50** is fastened to the other elements of the shear wall **10**, the shear wall **10** comprises a substantially rigid structure that inhibits lateral movement of the shear wall **10** in response to forces caused by seismic events and wind events. Since the shear wall **10** is coupled to the wall **12**, the inhibition of movement by the shear wall **10** causes movement of the wall **12** to be inhibited. By inhibiting the movement of the shear wall **10**, the wall **12** is protected from large movements during the events. As discussed above, the structural sheet may comprise one or more sheets of plywood, or, the structural sheet may comprise a laminated panel of steel or another metallic material, as described, for example, in U.S. Pat. No. 5,768,841, the disclosure of which is incorporated by reference herein.

[0028] As discussed above, the mudsill **20** is conventionally constructed from 2x4 or 2x6 lumber having a nominal thickness of 1.5 inches thick. The building codes in California, for example, were recently revised to require the mudsill **20** to be constructed from 3x4 or 3x6 lumber having a nominal thickness of 2.5 inches thick in order to inhibit compression and crushing of the mudsill **20**. The present invention may allow conventional 2x4 or 2x6 lumber to continue to be used. In particular, as shown in FIG. 3 for the end post **40**, the lower end of each end post **40, 42** has a compression post **60** mounted thereon.

[0029] As shown in FIG. 2, the compression post **60** comprises a steel plate **62** and a steel extended portion **64** that is oriented substantially perpendicular to the plane of the plate **62**. Preferably, the plate **62** has a generally rectangular shape selected to conform with the lower ends of the end posts **40, 42**. For example, for a 4x4 compression post, the plate **62** advantageously is shaped as a square having dimensions of approximately 3.5 inches by 3.5 inches to conform with the nominal dimensions of 4x4 lumber. If larger posts are used or if posts that are not square (e.g., 4x6 posts) are used, the size and shape of the plate **62** is advantageously selected accordingly. In advantageous embodiment, the plate **62** has a thickness of approximately

0.25 inch. The plate **62** advantageously includes a pair of holes **66** through which screws, nails or other fasteners can be inserted to engage the bottom of the end post **40, 42** to secure the compression post **60** to the end post **40, 42**.

[0030] In the illustrated embodiment, the extended portion **64** is cylindrical and advantageously comprises a steel tube having an outer diameter of approximately 1.625 inches and an inner diameter of 1.25 inches such that the walls of the cylinder are approximately 0.1875 (three-eighths) inch thick. In the embodiment illustrated in FIG. 3, one end of the cylindrical extended portion **64** is welded to the plate **62** such that the extended portion **64** is mounted perpendicularly to the plate **62**. Preferably, the inner circumference of the cylinder **64** is welded to the plate **62** by a plurality of spot welds **68** such that the outer surface of the cylinder **64** does not have any welding fillets and thus remains substantially round. The opposite end of the cylinder **64** is a free end **65**. Although illustrated herein as being hollow, the cylinder **64** can also advantageously comprise a solid material (e.g., a steel rod). The outer diameter of the cylinder **64** and the thickness of the cylinder wall (when a hollow cylinder is used) can be selected according to strength requirements established by an engineer of record for a construction project.

[0031] Although the extended portion **64** is illustrated herein as a cylinder having a circular cross section, one skilled in the art will appreciate that the extended portion **64** may have other shapes. For example, the extended portion **64** may advantageously have a rectangular shape. For 4x4 end posts **40, 42** and other end posts having a square cross section, the rectangular extended portion **64** may have a square cross section. For non-square end posts **40, 42** (e.g., 4x6 end posts), the rectangular extended portion **64** may have sides with dimensions proportional to the dimensions of the end posts **40, 42**.

[0032] Although the extended portion **64** may have alternative shapes, for convenience in describing the illustrated embodiment, the extended portion **64** is referred to below as the cylinder **64**.

[0033] The length of the cylinder **64** is selected to be approximately 1.5 inches thick. In particular, as shown in FIG. 3, the length of the cylinder **64** is selected to conform to the thickness of the mudsill **20** such that when the cylinder **64** is inserted in a hole **70** in the mudsill **20**, the plate **62** rests on top of the mudsill **20** and the free end **65** of the cylinder **64** rests on the footing **22**. Thus, the weight of the end post **42** is communicated directly to the footing **22** via the compression post **60** rather than being applied to the mudsill **20**. More importantly, when the forces caused by a seismic event or a severe wind event are applied to the end post **40** (or the end post **42**), the forces are transmitted directly to the footing **22** without compressing the mudsill **20**. Thus, the fibers of the mudsill **20** are not crushed by the end post **40**, and the additional movement that would have been allowed by the crushed mudsill **20** does not occur. By reducing the movement in this manner, the damage to the structure that would have otherwise occurred is reduced or eliminated. Furthermore, the compression post **60** permits the use of a conventional mudsill and conventional studs so that the benefits of reduced seismic and wind damage are obtained without a significant increase in construction costs.

[0034] Preferably, the diameter of the hole **70** formed in the mudsill **20** is selected to be slightly larger than the outer

diameter of the cylinder **64** so that the cylinder **64** can be easily inserted into the hole **70** during construction while limiting the lateral movement of the cylinder **64** within the hole **70**. In preferred embodiments, the diameter of the hole **70** is selected to be approximately 0.0625 inch ($\frac{1}{16}$ inch) larger than the outer diameter of the cylinder **64**. For example, in the illustrated embodiment, the hole **70** has a diameter of approximately 1.6875 inches ($1\frac{11}{16}$ inches) to accommodate a cylinder **64** having a diameter of 1.625 inches ($1\frac{5}{8}$ inches).

[0035] Although described herein with respect to a 1.5-inch thick mudsill **20**, a longer cylinder **64** can be used with thicker mudsills in jurisdictions which continue to require the thicker mudsill. Even with a thicker mudsill, compression will occur using conventional construction, and the compression post **60** reduces the compression.

[0036] In an alternative embodiment illustrated in **FIG. 4**, the cylinder **64** may be press fit into a suitably sized opening formed in the plate **62** so that spot welding is not needed.

[0037] In another alternative embodiment illustrated in **FIG. 5**, the cylinder **64** is not fixed to the plate **62**. Rather, the cylinder **64** is initially provided as an independent element. During construction of the shear wall, the cylinder **64** is positioned through each hole **70** in the mudsill **20** independently of the respective plate **62**. The plates **62** are secured to the bottoms of the end posts **40, 42**, as discussed above. When the end posts **40, 42** are positioned over the holes **70** in the mudsill **20**, the plates **62** engage the cylinders **64** and the forces applied to the end posts **40, 42** are communicated through the cylinders **64** to the footing **22**, as discussed above. In this alternative embodiment, the lengths of the cylinders **64** can be selected to accommodate the thickness of the mudsill at a particular location in the structure under construction. Thus, a plurality of sizes of plates **62** can be stocked to accommodate a variety of sizes of end posts and a plurality of lengths of cylinders **64** can be stocked to accommodate a variety of thicknesses of mudsills. A combination of plate size and cylinder length can be selected for a particular job requirement.

[0038] In another alternative embodiment illustrated in **FIG. 6**, a fastening system secures the cylinder **64** to the plate **62**. The cylinder **64** includes an endcap **72**. A bolt **74** is inserted through a bore **75** in the endcap **72**. A threaded portion of the bolt **74** engages a threaded bore **76** in the plate **62** to secure the cylinder **64** to the plate **62**. A washer **78** is advantageously included between the head of the bolt **74** and the endcap **72**. The washer **78** is advantageously a lock washer.

[0039] In another alternative embodiment illustrated in **FIG. 7**, the extended portion (e.g., cylinder) **64** and the plate **62** are cast as a unitary body. Although shown as a hollow cylinder **64** in **FIG. 7**, the extended portion **64** can also be cast as a solid body. Furthermore, as discussed above, it should be understood that the extended portion **64** can be advantageously cast in other shapes (e.g., rectangular).

[0040] In another alternative embodiment illustrated in **FIG. 8**, an outer perimeter of a portion of the upper end of the cylinder **64** has threads **80** formed thereon. A threaded bore **82** is formed through the plate **62** to receive the threads **80** of the cylinder **64** to secure the cylinder **64** to the plate **62**.

[0041] One skilled in art will appreciate that the foregoing illustrated embodiment and alternatives thereto are illustrative of the present invention. The present invention can be advantageously incorporated into further alternative embodiments while remaining within the spirit and scope of the present invention, as defined by the appended claims.

We claim:

1. A compression post for a shear wall positioned on a structural support, the compression post comprising:

a plate mounted to a lower end of an end post of a shear wall, the plate having dimensions selected to conform to the lower end of the end post; and

an extended portion positioned generally perpendicular to the plate, the extended portion having at least one dimension selected to fit through a hole in a mudsill of the shear wall and having a length selected to conform with a thickness of the mudsill such that when the shear wall is mounted on the structural support, forces applied to the end post are communicated via the plate and the extended portion to the structural support.

2. The compression post of claim 1, wherein the extended portion is secured to the plate.

3. The compression post of claim 1, wherein the extended portion is secured to the plate by at least one weld.

4. The compression post of claim 1, wherein the extended portion is secured to the plate by press fitting an end of the extended portion into a recess in the plate.

5. The compression post of claim 1, wherein:

one end of the extended portion is threaded;

the plate includes a threaded bore; and

the threaded end of the extended portion is engageable with the threaded bore to secure the extended portion to the plate.

6. The compression post of claim 1, further comprising:

an endcap on at least one end of the extended portion, the endcap having a bore there through;

a threaded bore in the plate; and

a bolt sized to extend through the bore of the endcap, the bolt having a threaded end engageable with the threaded bore in the plate to secure the extended portion to the plate.

7. The compression post of claim 1, wherein the extended portion and the plate comprise a cast unitary body.

8. The compression post of claim 1, wherein the extended portion is cylindrical and the at least one dimension is an outside diameter.

9. A shear wall mountable on a structural support, the shear wall having a first end, a second end, a bottom and a top, the shear wall comprising:

a mudsill at the bottom of the shear wall;

a double top plate at the top of the shear wall;

a plurality of studs positioned between the mudsill and the double top plate;

a first end post at the first end of the shear wall, the first end post having a lower end;

a second end post at the second end of the shear wall, the second end post having a lower end;

a structural sheet mounted to the mudsill, the double top plate, the studs, the first end post and the second end post to form a rigid structure; and

a first compression post positioned at the lower end of the first end post and a second compression post positioned at the lower end of the second end post, each compression post comprising:

a plate mounted to the respective lower end of the respective end post, the plate having dimensions selected to conform to the lower end of the end post; and

an extended portion positioned perpendicularly to the plate, the extended portion having at least one dimension selected to fit through a hole in the mudsill and having a length selected to conform to a thickness of the mudsill such that when the shear wall is mounted on the structural support, forces applied to the end post are communicated via the plate and the extended portion to the structural support.

10. The shear wall of claim 9, wherein the extended portion is secured to the plate.

11. The shear wall of claim 9, wherein the extended portion is secured to the plate by at least one weld.

12. The shear wall of claim 9, wherein the extended portion is secured to the plate by press fitting an end of the extended portion into a recess in the plate.

13. The compression post of claim 9, wherein:

one end of the extended portion is threaded;

the plate includes a threaded bore; and

the threaded end of the extended portion is engageable with the threaded bore to secure the extended portion to the plate.

14. The compression post of claim 9, further comprising: an endcap on at least one end of the extended portion, the endcap having a bore there through;

a threaded bore in the plate; and

a bolt sized to extend through the bore of the endcap, the bolt having a threaded end engageable with the threaded bore in the plate to secure the extended portion to the plate.

15. The compression post of claim 9, wherein the extended portion and the plate comprise a cast unitary body.

16. The shear wall of claim 9, wherein the extended portion is cylindrical and the at least one dimension is an outside diameter.

17. A method of reducing the lateral movement of a shear wall during a seismic event or a wind event, the method comprising:

constructing a shear wall having a first end post and a second end post mounted between a mudsill and a double top plate;

positioning a respective compression post proximate a lower end of each end post, the compression post having an extended portion that passes through a hole in the mudsill; and

positioning the shear wall on a structural support with respective exposed ends of the extended portions of the compression posts resting on the support such that forces applied to the end posts are communicated to the support via the compression posts rather than via the mudsills.

* * * * *